



Lubricant Management System

Multi-function contamination control

Features

- Dual-stage filtration
- Dedicated pump and motor per tank
- Filter bypass
- Stackable design
- 75, 150 & 300 gallon tank options
- Breather mounting kits to keep oil dry

Benefits

- Allows for more valuable floor space
- Allows for use with many lubricant types
- Eliminates cross-contamination



The Des-Case Lubricant Management System (LMS) combines filtration and breather technologies to keep your lubricants clean and dry before they enter your equipment.

Combining easy storage with solid contamination control practices, the sturdy, stackable, and customizable pods free up valuable floor space. Features like dual-stage filtration, timers, quick disconnects, and desiccant breather filters make this all-in-one system ideal for any lube storage room.

*Keeping contamination
under control.®*

Lubricant Management System Specifications

Applications

- Lubricant storage
- Dispensing new oil
- Pre-filtering new oil
- Reservoir top offs
- Collecting oil samples for analysis

Performance

1. Operating Temperatures:
 - -40 °F to 150 °F (-40 °C to 66 °C)

Materials:

- Stand and Tanks: Carbon Steel
 - Paint: Industrial Powder Coat
 - Filter Heads: Aluminum
 - Fittings: Brass, and/or Zinc Plated Steel
 - Pumps: Aluminum/Steel
 - Internal Plumbing: Nitrate (Buna-N)
 - Hoses: Clear PVC with steel wire
2. Filter Indicators and Bypass:
 - Filter indicator pops at 22 psid (1.55 bar) as warning that filter elements need to be replaced
 - Automatic filter bypass at 25 psid (1.75 bar)
 3. Dimensions:
 - 75 gallon tank 50.50"L x 30"W x 22"H
 - 150 gallon tank 50.50"L x 30"W x 44"H
 - 300 gallon tank 50.50"L x 60"W x 44"H
 4. Viscosity Range: ISO 10-680 (55-4000 SUS at 100°F)

Item No.	Description	Qty.
1	Inlet Hose	1
2	Outlet Hose	1
3	Left Ball Valve	1
4	Right Ball Valve	1
5	Pressure Gauges	3
6	Filter Elements	2
7	Remote Mount Gravity Drain*	1-2
8	Filter Bypass Valve	1
9	Gravity Drain	1

*One drain per stackable tank

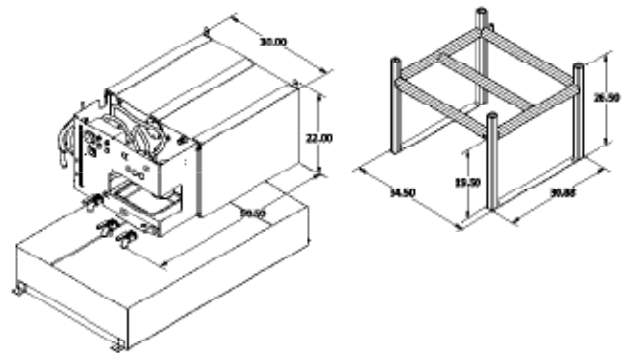
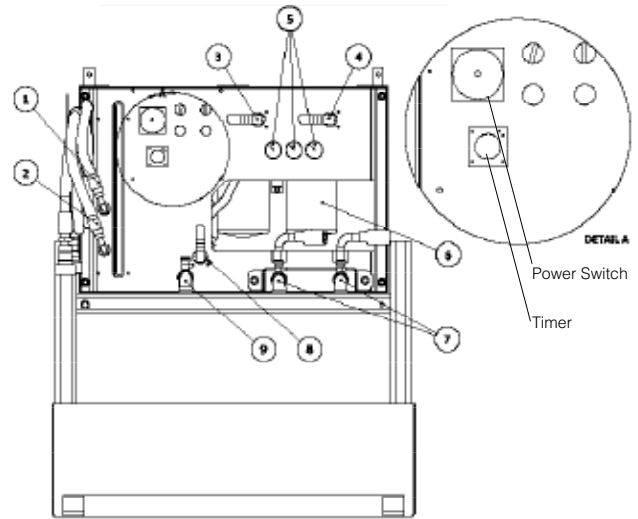

Element Replacements

FC-KF	FC-LF	FC-MF	FC-NF	FC-WF
3um	6um	12um	25um	Water Removal

*Other micron sizes available upon request

How to order the Lubricant Management System:

Select the desired symbol (in the correct position) to construct a model code. Then contact your local distributor or call Des-Case if you don't see the options you need or would like additional assistance.

	Box 1	Box 2	Box 3	Box 4	Box 5	Box 6	Box 7	Box 8	Box 9	Box 10	Box 11	Box 12	Box 13	Box 14
FL	C Upper Unit													
FL	B Middle Unit													
FL	A Lower Unit													

TANK SIZE [Box 2]

Code	Description
75	75-gallon steel tank (stackable three high)
150	150-gallon steel tank (non-stackable)
300	300-gallon steel tank (non-stackable)

PUMP / MOTOR COMBINATIONS * [Box 3]

Code	Description
60 Hz Options	
02E	2 gpm / 1 hp electric, 115 vac, 60 hz, 1725 rpms, 13 amps
02F	2 gpm / 1 hp electric, 230 vac, 60 hz, 1725 rpms, 6.5 amps
05E	5 gpm / 1 hp electric, 115 vac, 60 hz, 1725 rpms, 13 amps
05F	5 gpm / 1 hp electric, 230 vac, 60 hz, 1725 rpms, 6.5 amps
50 Hz Options	
02G	2 gpm / 1 hp electric, 110 vac, 50 hz, 1425 rpms, 12.4 amps
02H	2 gpm / 1 hp electric, 220 vac, 50 hz, 1425 rpms, 6.2 amps
05G	5 gpm / 1 hp electric, 110 vac, 50 hz, 1425 rpms, 12.4 amps
05H	5 gpm / 1 hp electric, 220 vac, 50 hz, 1425 rpms, 6.2 amps

* Performance will vary depending on operating temperature, fluid type and unit options. Call Des-Case for assistance in choosing a flow rate specific to your needs.

TANK INCOMING / SUCTION CONNECTION TYPE [Box 4]

Code	Description
F	Flush Face Connector
A	ISO A Connector
B	ISO B Connector

TANK INCOMING / SUCTION CONNECTION SIZE [Box 5]

Code	Description
5	3/4 inch
7	1 inch

TANK OUTGOING / PRESSURE CONNECTION TYPE [Box 6]

Code	Description
F	Flush Face Connector
A	ISO A Connector
B	ISO B Connector

TANK OUTGOING / PRESSURE CONNECTION TYPE [Box 7]

Code	Description
3	1/2 inch
5	3/4 inch
7	1 inch

FILTER A [Box 8] / FILTER B [Box 9]

Code	Description
K	3-micron Particulate Filter
L	6-micron Particulate Filter
M	12-micron Particulate Filter
N	25-micron Particulate Filter
W	Water Filter

* Filter indicator pops at 22 psid.

MANUAL FILTER BYPASS [Box 10]

Code	Description
0	No Bypass
1	Filter Bypass

SAMPLE PORTS [Box 11]

Code	Description
0	None
1	Sample Port
2	High-Viscosity

MANUAL GRAVITY DRAIN [Box 12]

Code	Description
0	No Drain
1	Gravity Drain

LEVEL SWITCHES [Box 13]

Code	Description
0	None
1	Level Switches
2	Level Switches and Pump Timer

BREATHER FILTERS [Box 14]

Code	Description	
2	3-micron particulate desiccant breather	[DC-2]
3	3-micron particulate desiccant breather	[DC-3]
4	3-micron particulate desiccant breather	[DC-4]

Call Des-Case for information about accessories such as spill containment reservoirs.

Try All Des-Case Fluid Handling & Filtration Products

Customize your filtration system today at www.descase.com/flowguard

Portable Filtration



Dedicated Filtration



Water Removal



Lubricant Storage & Filtration



Filter Elements



Adapter Kits

